



VC7916

**RF Power Amplifier For Quad-Band
GSM/GPRS/EDGE /TD-SCDMA/TD-LTE With
SP16T Antenna Switch**

Product ID VC7916

Version V1.0

Vanchip Technologies

Version 1.0

Preliminary Datasheet
Vanchiptech Confidential

*Products and Product Information are Subject to Change Without Prior Notice

Revision History

Version	Date	Author	Modify Description
1.0	Aug 2015	Vanchip	Preliminary Release

Features

- Small package: 5.5 x 5.3 x 0.83mm
- 8KV ESD Protection at Antenna Port
- MIPI RFFE Digital Interface
- Integrate Antenna Switches
- High Linear EDGE Operation
- High Efficiency
 - GSM850/GSM900 38%
 - DCS1800/PCS1900 32%
- 14 Low Insertion Loss TRx Port
- TRX Ports interchangeable and DC-Block capacitor less
- Integrated Low Pass TX Harmonic Filter
- Advanced HBT/CMOS/SOI Process
- GPRS multi-mode capability Class 12
- Support TD-SCDMA B34/B39
- Support TDD-LTE B39

Product Description

The VC7916 is a high-power, high-efficiency transmit and receive Front-End Module for Quad-band GSM850/GSM900/DCS1800/PCS1900 operation . The FEM also support Class 12 GPRS multi-slot operation ,linear EDGE operation ,TD-SCDMA HSPA and TDD-LTE.

This FEM builds upon Vanchip’s unique power amplifier technology to provide maximum efficiency and Pout, build in current and voltage regulating technology stable TRP performance under load mismatch. Integrated antenna switch module reduce PCB size, interchangeable TRX ports are easy for layout and application. The module provides 50ohm matched input and output ports and integrated TX low pass filter can achieve best-in class harmonic performance.

The VC7916 can sustain 8KV ESD at Antenna port, without external components needed. The module can sustain 20:1 VSWR on Antenna Port under mismatch condition.

VC7916 Function Block Diagram

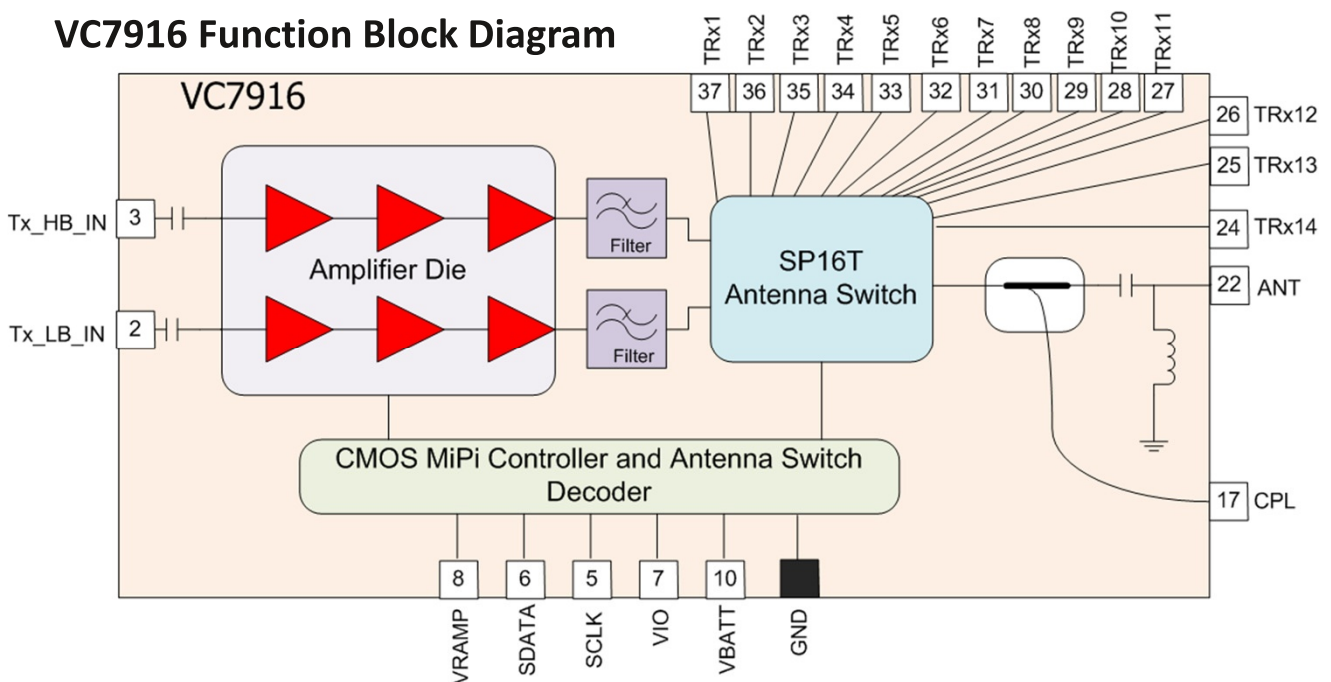

Absolute Maximum Ratings

Parameter	Rating	Unit
Supply	-0.3 to +6	V
Power Control Voltage (Vramp)	-0.3 to +1.8	V
Input RF Power	10	dBm
Max Duty Cycle	50	%
Output Load VSWR	20:1	
Operating Case Temperature	-25 to +85	C
Storage Temperature	-55 to +150	C
ESD Antenna Port	8	kV
ESD All Pins (Charge Device Model)	1000	V
ESD All Pins (Human Body Model)	1000	V

Recommended Operating Conditions

Parameter	Min	Typ.	Max	Unit	Test Condition
Supply Voltage VCC	3.1	3.5	4.35	V	
Supply Voltage VBATT	3.1	3.5	4.35	V	
MIPI Supply	1.7	1.8	1.9	V	Vramp≤1.8V
MIPI Signal Level	0		0.2*VIO	V	Signal Level Low
	0.8*VIO	1.8	VIO	V	Signal Level High
Leakage Current			20	uA	Applied DC Only: VCC=VBATT=4.35V,
TRx Mode Current		100	300	uA	
Operating temperature	-20	+25	+85	°C	

MIPI RFFE REGISTER MAP

Register Address	Data Bit	Description	Default	Notes
0x0000	[7:5]	Reserved	000	Reserved
	[4:0]	Mode Control	00000	Standby=0x00 LB_GMSK Tx=0x0A HB_GMSK Tx=0x0E LB_EDGE Tx=0x0B HB_EDGE Tx=0x0F TD-SCDMA/TDD LTE Tx=0x0F TRx1=0x10 TRx2=0x18 TRx3=0x03 TRx4=0x02 TRx5=0x01 TRx6=0x05 TRx7=0x09 TRx8=0x0D TRx9=0x04 TRx10 = 0x08 TRx11 = 0x14 TRx12 = 0x1C TRx13 = 0x11 TRx14 = 0x19 Isolation=0x06 Isolation=0x07 Isolation=0x0C
0x0001	[7:4]	High Band Vreg Reference	1000	0000=2.6V 0001=2.65V 0100=2.80V 0111=2.95V 1010=3.10V 1101=3.25V 0010=2.70V 0101=2.85V 1000=3.00V 1011=3.15V 1110=3.30V 0011=2.75V 0110=2.90V 1001=3.05V 1100=3.20V 1111=3.35V
	[3:0]	Low Band Vreg Reference	1000	0000=2.6V 0001=2.65V 0100=2.80V 0111=2.95V 1010=3.10V 1101=3.25V 0010=2.70V 0101=2.85V 1000=3.00V 1011=3.15V 1110=3.30V 0011=2.75V 0110=2.90V 1001=3.05V 1100=3.20V 1111=3.35V
0x0002	[7:0]	Reserved	0x00	Reserved
0x0003	[7:0]	Reserved	0x00	Reserved
0x0004	[7:0]	Reserved	0x00	Reserved
0x001C	[7:6]	PWR_MODE	00	00=Normal Operation (ACTIVE) 01=Default Settings (STARTUP) 10=Low Power (LOW POWER) 11=Reserved
	[5]	Trigger_Mask_2	1	0:Trigger Enable 1:Trigger Disable
	[4]	Trigger_Mask_1	1	0:Trigger Enable 1:Trigger Disable
	[3]	Trigger_Mask_0	1	0:Trigger Enable 1:Trigger Disable
	[2]	Trigger_2	0	Not Support
	[1]	Trigger_1	0	Reserved
	[0]	Trigger_0	0	1 = Latch Register 0, 1 contents
0x001D	[7:0]	Product_ID	0x85	Product ID = 0x85
0x001E	[7:0]	Manufacturer_ID[7:0]	0x38	Manufacture ID[7:0] = 0x38
0x001F	[7:6]	Reserved	00	Reserved
	[5:4]	Manufacturer_ID[9:8]	11	Manufacture ID[9:8] = 0x11
	[3:0]	USID	1111	USID = 1111

Electrical Specifications GSM850 GMSK Mode

Test Condition:

Frequency= 824 to 849 MHz, Temperature= 25°C , Vbat= 3.5V, Pin= 3dBm, Vramp=1.8V

Parameter	Min.	Tpy.	Max.	Unit	Condition
Operation Frequency	824		849	MHz	
Input Power	0	3	6	dBm	Max Pout should guaranteed at Min input power
Max output power	33	34		dBm	Nominal Condition
	31.0			dBm	Extreme Condition (Temperature range -20 to 85°C)
Input VSWR			2.5:1		Pout=5 to 33dBm Pin≤6dBm
Efficiency		38		%	Pout=33dBm; duty cycle = 1:8
Max Supply Current under mismatch			2.3	A	VSWR=10:1; Vramp=Vramp_rated
Forward Isolation 1		-52	-45	dBm	Pin=6dBm, Vramp=0.16V
Forward Isolation 2			-15	dBm	Pin=6dBm, Vramp=0.16V
2nd Harmonic*		-40	-33	dBm	Pout≤33dBm
3rd Harmonic*		-40	-33	dBm	Pout≤33dBm
All other harmonic* (< 12.75GHz)			-33	dBm	Pout≤33dBm
All other non-harmonic * (<12.75GHz)			-36	dBm	Pout=5 to 33dBm Pin≤6dBm
Noise Power			-84	dBm	f=869 to 894MHz, Pout=33dBm, RBW=100KHz
			-83	dBm	f=1930 to 1990MHz, Pout=33dBm, RBW=100KHz

*External filter can optimize high order harmonic performance

Electrical Specifications GSM900 GMSK Mode

Test Condition:

Frequency= 880 to 915 MHz, Temperature= 25°C , Vbat= 3.5V, Pin= 3dBm, Vramp= 1.8V

Parameter	Min.	Tpy.	Max.	Unit	Condition
Operation Frequency	880		915	MHz	
Input Power	0	3	6	dBm	Max Pout should guaranteed at Min input power
Max output power	33	34		dBm	Nominal Condition
	31.5			dBm	Extreme Condition (Temperature range -20 to 85°C)
Input VSWR			2.0:1		Pout=5 to 33dBm Pin≤6dBm
Efficiency		38		%	Pout=33dBm; duty cycle = 1:8
Max Supply Current under mismatch			2.3	A	VSWR=10:1; Vramp=Vramp_rated
Forward Isolation 1		-52	-48	dBm	Pin=6dBm, Vramp=0.16V
Forward Isolation 2			-15	dBm	Pin=6dBm, Vramp=0.16V
2nd Harmonic*		-40	-33	dBm	Pout≤33dBm
3rd Harmonic*		-40	-33	dBm	Pout≤33dBm
All other harmonic* (< 12.75GHz)			-33	dBm	Pout≤33dBm
All other non-harmonic * (<12.75GHz)			-36	dBm	Pout=5 to 33dBm Pin≤6dBm
Noise Power			-84	dBm	f=925 to 935MHz, Pout=33dBm, RBW=100KHz
			-84	dBm	f=935 to 960MHz, Pout=33dBm, RBW=100KHz
Operation Frequency			-83	dBm	f=1805 to 1880MHz, Pout=33dBm, RBW=100KHz

* External filter can optimize high order harmonic performance

Electrical Specifications DCS1800 GSMK Mode

Test Condition:

Frequency= 1710 to 1785 MHz, Temperature= 25°C , Vbat= 3.5V, Pin= 3dBm, Vramp= 1.8V

Parameter	Min.	Tpy.	Max.	Unit	Condition
Operation Frequency	1710		1785	MHz	
Input Power	0	3	6	dBm	Max Pout should guaranteed at Min input power
Max output power	30	32		dBm	Nominal Condition
	28			dBm	Extreme Condition (Temperature range -20 to 85°C)
Input VSWR			2.0:1		Pout=5 to 30dBm Pin≤6dBm
Efficiency		32		%	Pout=30dBm; duty cycle = 1:8
Max Supply Current under mismatch			1.5	A	VSWR=10:1; Vramp=Vramp_rated
Forward Isolation 1		-50	-46	dBm	Pin=6dBm, Vramp=0.16V
Forward Isolation 2			-15	dBm	Pin=6dBm, Vramp=0.16V
2nd Harmonic*		-40	-33	dBm	Pout≤30dBm
3rd Harmonic*		-40	-33	dBm	Pout≤30dBm
All other harmonic* (< 12.75GHz)			-33	dBm	Pout≤30dBm
All other non-harmonic * (<12.75GHz)			-36	dBm	Pout=5 to 30dBm Pin≤6dBm
Noise Power			-84	dBm	f=925 to 935MHz, Pout=30dBm, Pin=6dBm, RBW=100KHz
			-84	dBm	f=935 to 960MHz, Pout=30dBm, Pin=6dBm, RBW=100KHz
Operation Frequency			-83	dBm	f=1805 to 1880MHz, Pout=30dBm, Pin=6dBm, RBW=100KHz

* External filter can optimize high order harmonic performance

Electrical Specifications PCS1900 GMSK Mode

Test Condition:

Frequency= 1850 to 1910 MHz, Temperature= 25°C , Vbat= 3.5V, Pin= 3dBm, Vramp= 1.8V,

Parameter	Min.	Tpy.	Max.	Unit	Condition
Operation Frequency	1850		1910	MHz	
Input Power	0	3	6	dBm	Max Pout should guaranteed at Min input power
Max output power	30	32		dBm	Nominal Condition
	28.5			dBm	Extreme Condition (Temperature range -20 to 85°C)
Input VSWR			2.5:1		Pout=5 to 30dBm Pin≤6dBm
Efficiency		32		%	Pout=30dBm; duty cycle = 1:8
Max Supply Current under mismatch			1.5	A	VSWR=10:1; Vramp=Vramp_rated
Forward Isolation 1		-50	-46	dBm	Pin=6dBm, Vramp=0.16V
Forward Isolation 2			-15	dBm	Pin=6dBm, Vramp=0.16V
2nd Harmonic*		-40	-33	dBm	Pout≤30dBm
3rd Harmonic*		-40	-33	dBm	Pout≤30dBm
All other harmonic* (< 12.75GHz)			-33	dBm	Pout≤30dBm
All other non-harmonic * (<12.75GHz)			-36	dBm	Pout=5 to 30dBm Pin≤6dBm
Noise Power			-84	dBm	f=869 to 894MHz, Pout=30dBm, Pin=6dBm, RBW=100KHz
			-83	dBm	f=1930 to 1990MHz, Pout=30dBm, Pin=6dBm, RBW=100KHz

*External filter can optimize high order harmonic performance

Electrical Specifications GSM850 EDGE Mode

Test Condition:

Frequency= 824 to 949 MHz, Temperature= 25°C , Vbat= 3.5V, Pin adjusted for required Pout,
Vramp = 1.8V

Parameter	Min.	Tpy.	Max.	Unit	Condition
Operation Frequency	824		849	MHz	
Input VSWR			2.5:1		
Max output power (Meet EVM and ACPR Spec)	27.5			dBm	Vramp= 1.8V
Gain		34		dB	Pout=27.5dBm
Efficiency		18		%	Pout=27.5dBm; duty cycle = 1:8
Max Supply Current		880		mA	Pout=27.5dBm
ACPR		-60	-57	dBc	At 400kHz in 30kHz BW, Pout =27.5dBm
EVM RMS			5	%	Pout=27.5dBm
Max Noise Power under mismatch			-36	dBm	Load VSWR=10:1
Noise Power			-84	dBm	f=869 to 894MHz, Pout=27.5dBm, RBW=100KHz
			-83	dBm	f=1930 to 1990MHz, Pout=27.5dBm, RBW=100KHz

Electrical Specifications GSM900 EDGE Mode

Test Condition:

Frequency= 880 to 915 MHz, Temperature= 25°C , Vbat= 3.5V, Pin adjusted for required Pout,
Vramp = 1.8V

Parameter	Min.	Tpy.	Max.	Unit	Condition
Operation Frequency	880		915	MHz	
Input VSWR			2.5:1		
Max output power (Meet EVM and ACPR Spec)	27.5			dBm	Vramp= 1.8V
Gain		34		dB	Pout=27.5dBm
Efficiency		18		%	Pout=27.5dBm; duty cycle = 1:8
Max Supply Current		880		mA	Pout=27.5dBm
ACPR		-60	-57	dBc	At 400kHz in 30kHz BW, Pout =27.5dBm
EVM RMS			5	%	Pout=27.5dBm
Max Noise Power under mismatch			-36	dBm	Load VSWR=10:1
Noise Power			-84	dBm	f=925 to 935MHz, Pout=27.5dBm, RBW=100KHz
			-84	dBm	f=935 to 960MHz, Pout=27.5dBm, RBW=100KHz
			-83	dBm	f=1805 to 1880MHz, Pout=27.5dBm, RBW=100KHz

Electrical Specifications DCS1800 EDGE Mode

Test Condition:

Frequency= 1710 to 1785 MHz, Temperature= 25°C , Vbat= 3.5V, Pin adjusted for required Pout, Vramp = 1.8V

Parameter	Min.	Tpy.	Max.	Unit	Condition
Operation Frequency	1710		1785	MHz	
Input VSWR			2.5:1		
Max output power (Meet EVM and ACPR Spec)	26.5			dBm	Vramp= 1.8V
Gain		34		dB	Pout=26.5dBm
Efficiency		16		%	Pout=26.5dBm; duty cycle = 1:8
Max Supply Current		830		mA	Pout=26.5dBm
ACPR		-60	-57	dBc	At 400kHz in 30kHz BW, Pout =26dBm
EVM RMS			5	%	Pout=26.5dBm
Max Noise Power under mismatch			-36	dBm	Load VSWR=10:1
Noise Power			-84	dBm	f=925 to 935MHz, Pout=26dBm, RBW=100KHz
			-84	dBm	f=935 to 960MHz, Pout=26dBm, RBW=100KHz
			-83	dBm	f=1805 to 1880MHz, Pout=26dBm, RBW=100KHz

Electrical Specifications PCS1900 EDGE Mode

Test Condition:

Frequency= 1850 to 1910 MHz, Temperature= 25°C , Vbat= 3.5V, Pin adjusted for required Pout, Vramp = 1.8V

Parameter	Min.	Tpy.	Max.	Unit	Condition
Operation Frequency	1850		1910	MHz	
Input VSWR			2.5:1		
Max output power (Meet EVM and ACPR Spec)	26			dBm	Vramp= 1.8V
Gain		33		dB	Pout=26.5dBm
Efficiency		16		%	Pout=26.5dBm; duty cycle = 1:8
Max Supply Current		830		mA	Pout=26.5dBm
ACPR		-60	-57	dBc	At 400kHz in 30kHz BW, Pout =26.5dBm
EVM RMS			5	%	Pout=26.5dBm
Max Noise Power under mismatch			-36	dBm	Load VSWR=10:1
Noise Power			-84	dBm	f=869 to 894MHz, Pout=26dBm, RBW=100KHz
			-83	dBm	f=1930 to 1990MHz, Pout=26dBm, RBW=100KHz

Electrical Specifications TD-SCDMA Mode

Test Condition:

Frequency= 1880 to 1920MHz, 2010 to 2025MHz, Temperature= 25°C, Vbat= 3.5V, Vramp=0V

Parameter	Min.	Tpy.	Max.	Unit	Condition
Operation Frequency	1880		1920	MHz	
	2010		2025	MHz	
Gain		28		dB	Pout=25dBm
Gain Flatness		±0.5		dB	Pout≤25dBm (HPM)
		±0.5		dB	Pin=-35dBm (LPM)
ACLR(±1.6MHz Offset)		-40	-36	dBc	Pout=25dBm
ACLR(±3.2MHz Offset)		-57	-48	dBc	Pout=25dBm
EVM			5	%	Pout=25dBm
Input VSWR		2.5:1			Pout=25dBm
Normal Working Current		550		mA	Pout=25dBm
Noise Power					
925MHz to 935MHz			-77	dBm	Pout=24dBm, RBW=100kHz
935MHz to 965MHz			-83	dBm	Pout=24dBm, RBW=100kHz
1805MHz to 1880MHz			-75	dBm	Pout=24dBm, RBW=100kHz
All other harmonic* (< 12.75GHz)			-33	dBm	Pout=24dBm

*External filter can optimize high order harmonic performance

Electrical Specifications TD-LTE Mode

TDD-LTE Band 39 VBAT =3.5 V at Room Temperature +25 C, Vramp=0V Test LTE signal with QPSK/10MHz/12RB					
Characteristics	Min	Typical	Max	Unit	Test Condition
Operating Frequency	1880	1900	1920	MHz	
Maximum Output Power (Pout_Max)	25			dBm	MPR = 0 (3GPP TS36.101)
Gain		29		dB	Pout=25dBm
Gain Flatness		0.5		dB	Pout=25dBm
Power Added Efficiency		17		%	Pout=25dBm
Supply Current		530		mA	POUT = 25 dBm, VBAT = 3.5 V
Adjacent Channel Leakage power Ratio		-42	-33	dBc	ACLR_EUTRA (Pout=25dBm)
		-42	-36	dBc	ACLR1_UTRA
		-52	-43	dBc	ACLR2_UTRA
Harmonic Suppression		-40	-33	dBm	2nd Harmonic
		-40	-33	dBm	3rd Harmonic
			-33	dBm	All other harmonics up to 12.75GHz
EVM			3.5	%	Pout = Pout_Max, Load = 50 ohms
DC ON/OFF Time			10	us	
RF ON/OFF Time			6	us	
Input VSWR		1.2:1	1.8:1	—	
Stability (Spurious output)			-36	dBm	At load VSWR = 10:1, all phases, RBW 1MHz POUT ≤ 25dBm
Ruggedness	20:1			—	No damage or Permanent Degradation at POUT ≤ 25dBm

Electrical Specifications TRX Mode

Test Condition:

Temperature = 25°C , Vbat = 3.5V, Vramp = 0V

UMTS RF Ports TRx1 to TRx14					
Parameter	Minimum	Typical	Maximum	Unit	Conditions
Frequency Range	699	—	2690	MHz	
Insertion Loss	—	0.7	1.0	dB	699 MHz to 960 MHz
	—	1	1.4	dB	1710 MHz to 1990 MHz
	—	1.4	1.8	dB	2010 MHz to 2690 MHz
TRx Mode Return Loss	—	—	-12	dB	NTC
Isolation (Active TRx port to any adjacent TRx port)	26	32	—	dB	699 MHz to 960 MHz
	22	28	—	dB	1710 MHz to 1990 MHz
	20	22	—	dB	2010 MHz to 2690 MHz
Isolation (Active TRx port to any non-adjacent TRx port)	35	40	—	dB	699 MHz to 960 MHz
	30	35	—	dB	1710 MHz to 1990 MHz
	25	28	—	dB	2010 MHz to 2690 MHz
TRx Harmonics (2fo, 3fo)	—	—	-55	dBm	Pwr_in_at TRx Port = +27 dBm
Second Order Intermodulation Distortion (IMD2)	—	—	-105	dBm	Pin = 20dBm; CW Blk Power = -15dBm
Third Order Intermodulation Distortion (IMD3)	—	—	-105	dBm	
Leakage power from Tx to TRx Ports	—	—	5	dBm	Any TX Mode
Coupling Factor in TRx Mode		-27		dB	699 to 960 MHz
		-23		dB	1710 to 1990 MHz
		-22		dB	2010 to 2690 MHz
Coupling Factor Variation over Output VSWR	1.0		-1.0	dB	699 to 2690 MHz, VSWR 3:1 at ANT port

EVB Schematic illustration

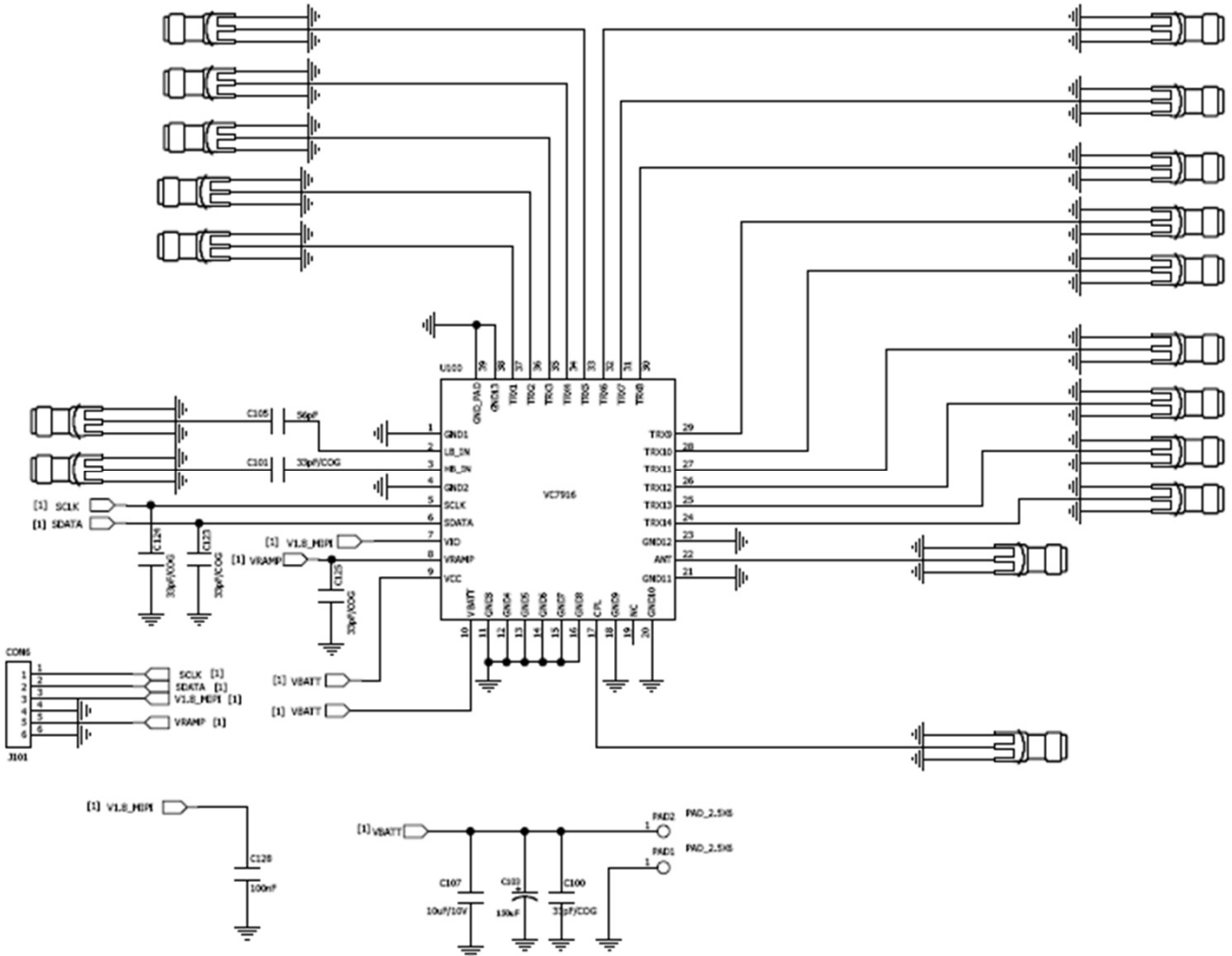

Note:

1. ALL RF Input and output Trace with 50 Ohm microstrip-line.
2. ANT Port reserve PI type component for improve harmonic performance
3. RFIN LB and RFIN HB DC-Block less.
4. All TRX port DC-Block less.

EVB illustration

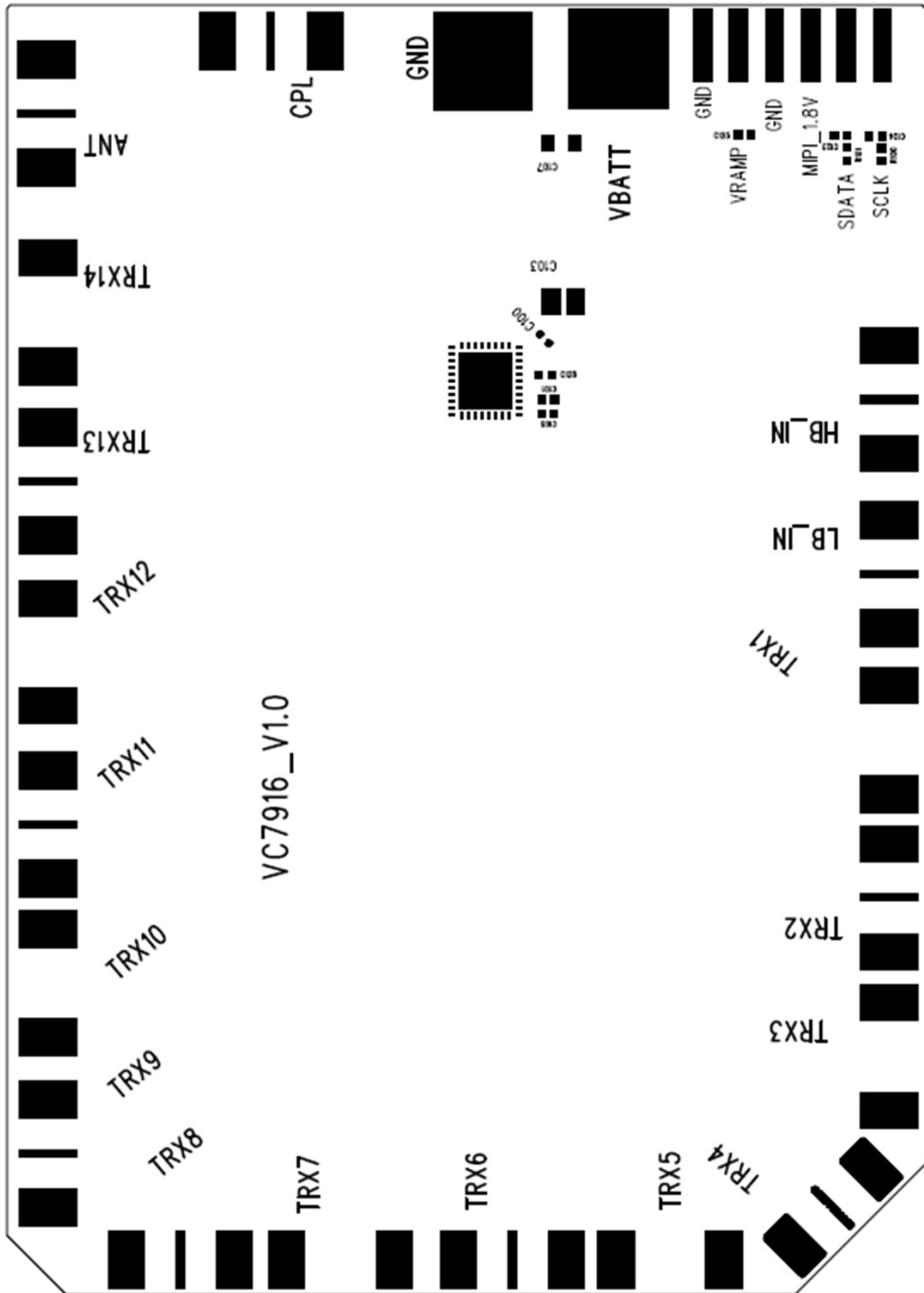

Preliminary Datasheet
Vanchiptech Confidential

Package Information

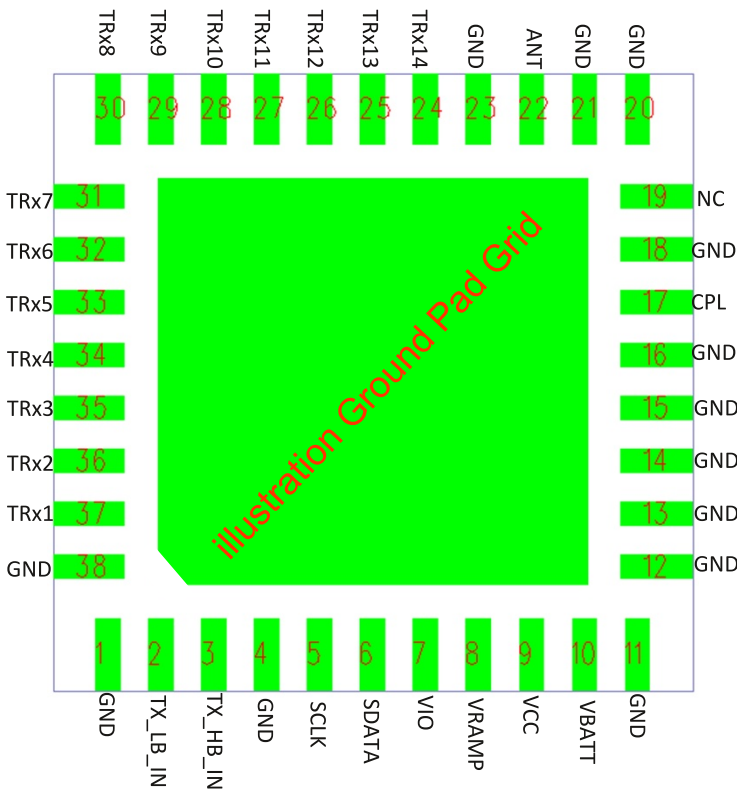
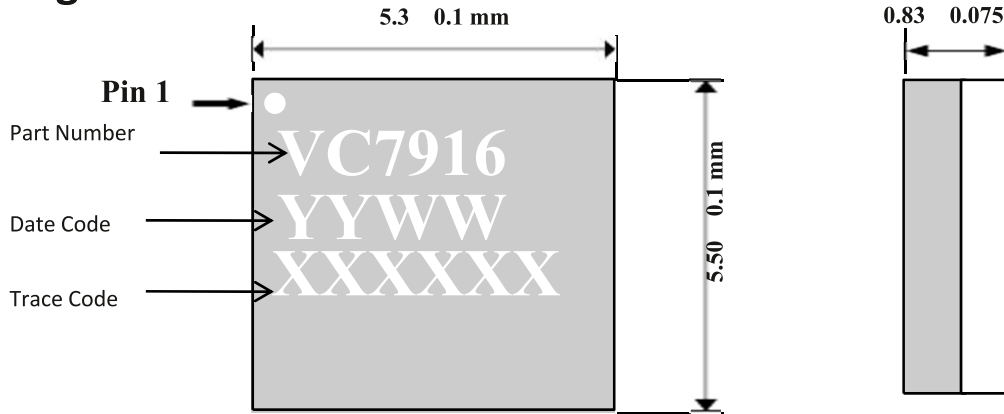

Pad	Name	Description
Gnd_Pad	GND	1,4,11-16,18,20,21,23,38 are ground pin; Ground PAD Grid under Device
2	Tx_LB_IN	Input Txsignal 824MHz-915 MHz
3	Tx_HB_IN	Input Txsignal 1710MHz-2025 MHz
5	SCLK	MiPi Clock
6	SDATA	MiPi Data
7	VIO	MiPi Power Supply
8	VRAMP	GMSK Controls GMSK power; EDGE, TD-SCDMA, TDD-LTE bias
9	VCC	Battery supply voltage
10	VBAT	Battery supply voltage
17	CPL	Directional coupler RF output
22	ANT	PA output to Antenna
19	NC	Not connect
24~37	TRx1~14	Wideband TRx switch port

Pad layout as seen from Top View looking through package

Package Outline Unit: mm

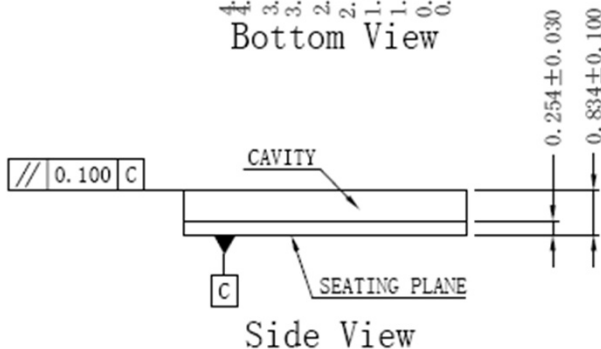
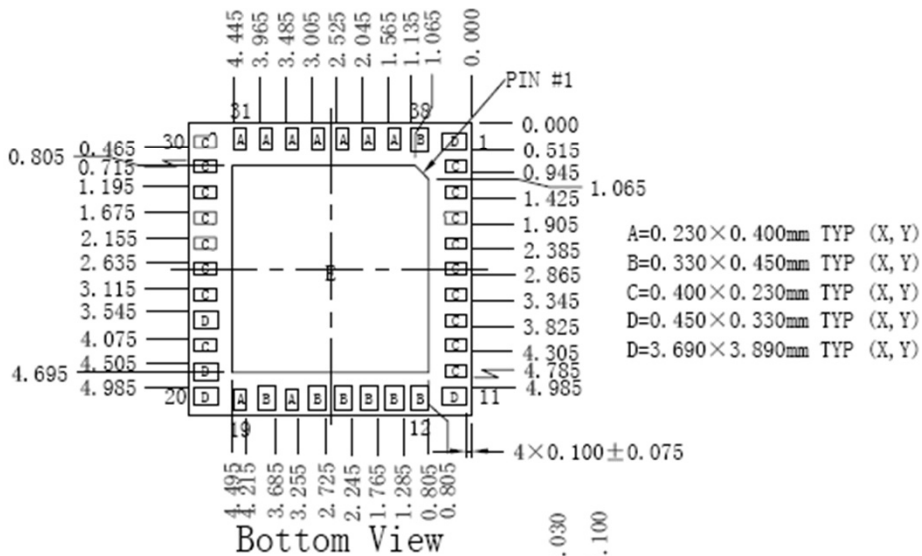
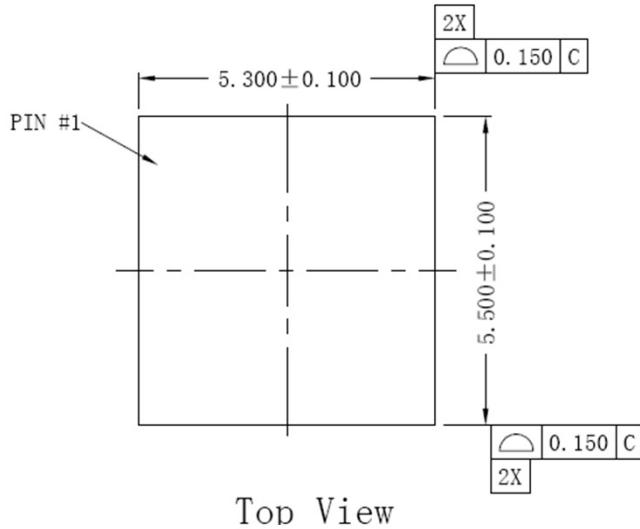

Note: Unless otherwise specified

1. All DIMENSIONS ARE IN MILLIMETERS.
2. DIMENSIONS AND TOLERANCING IN ACCORDANCE WITH ASME Y14.5M-1994.

PCB Layout Footprint Recommendation Unit: mm

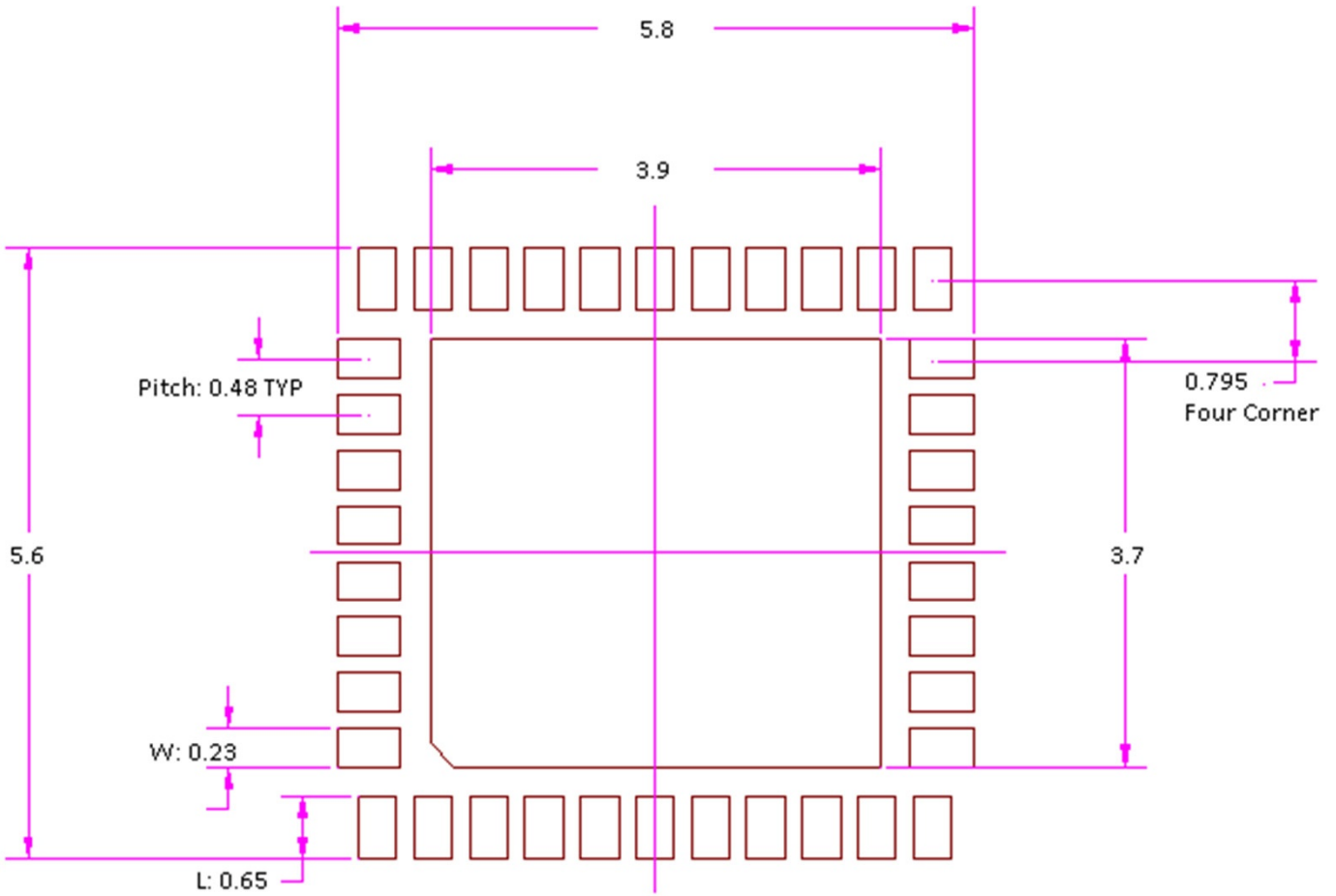

For PCB Metal/ Stencil
 Pin to Pin Pitch: 0.48
 L: 0.65
 W: 0.23

For PCB Solder mask
 Pin to Pin Pitch: 0.48
 L: 0.750
 W: 0.33

Note: Unless otherwise specified

1. All DIMENSIONS ARE IN MILLIMETERS.
2. DIMENSIONS AND TOLERANCING IN ACCORDANCE WITH ASME Y14.5M-1994.

Tape and Reel

VC7916 carrier tape basic dimensions are based on EIA 481. The pocket is designed to hold the part for shipping and loading onto SMT manufacturing equipment, while protecting the body and the solder terminals from damaging stresses.

Prior to shipping, moisture sensitive parts (MSL level 2a-5a) are baked and placed into the pockets of the carrier tape. A cover tape is sealed over the top of the entire length of the carrier tape. The reel is sealed in a moisture barrier ESD bag with the appropriate units of desiccant and a humidity indicator card, which is placed in a cardboard shipping box. It is important to note that unused moisture sensitive parts need to be resealed in the moisture barrier bag. If the reels exceed the exposure limit and need to be rebaked, most carrier tape and shipping reels are not rated as bakeable at 125° C.

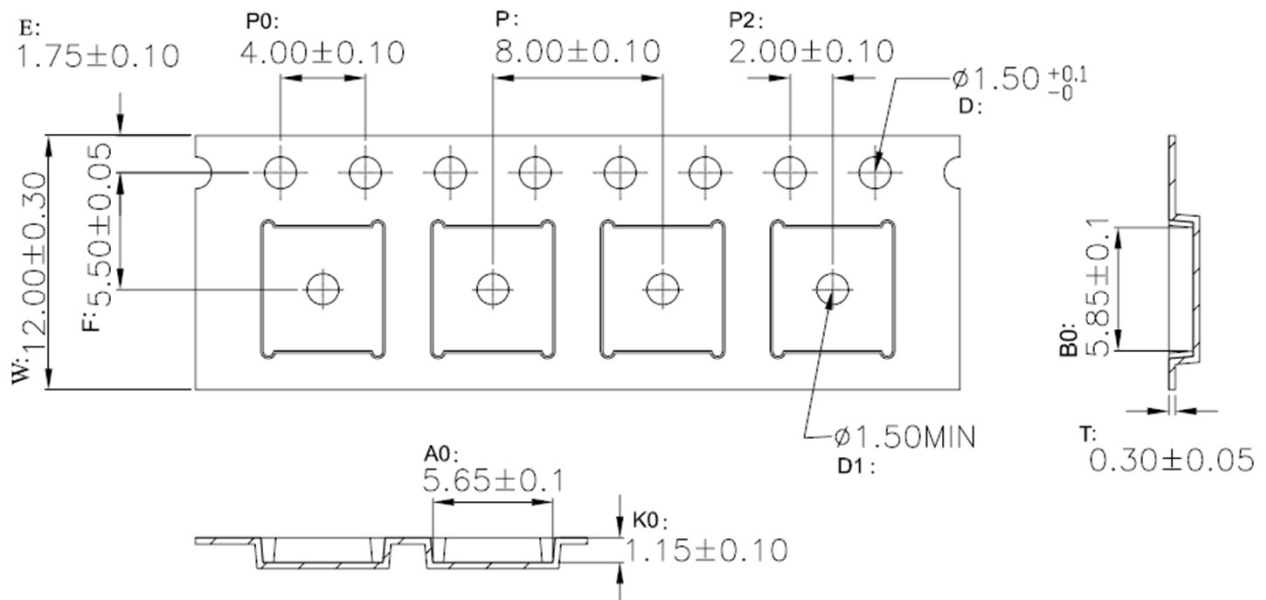

TECHNOLOGY SPECIFICATION

1. CARRIER TAPE COLOR:BLACK.
2. ANTISTATIC COATED 10⁵~10¹¹OHMS/SQ.
3. 10 SPROCKET HOLE PITCH CUMULATIVE TOLERANCE ±0.20MAX.
4. CAMBER NOT TO EXCEED 1 MM IN 100 MM.
5. MOLD# BGA/LGA (5.5×5.3) .
6. COVER TAPE WIDTH:9.3mm±0.1mm.
7. COVER TAPE COLOR:TRANSPARENT
8. BAN TO USE THE LEVEL 1 ENVIRONMENT-RELATED SUBSTANCES OF JCET PRESCRIBING.
9. ALL UNITS ARE IN MILLIMETER;
10. THE DIRECTION OF VIEW: